

SECTION A-A

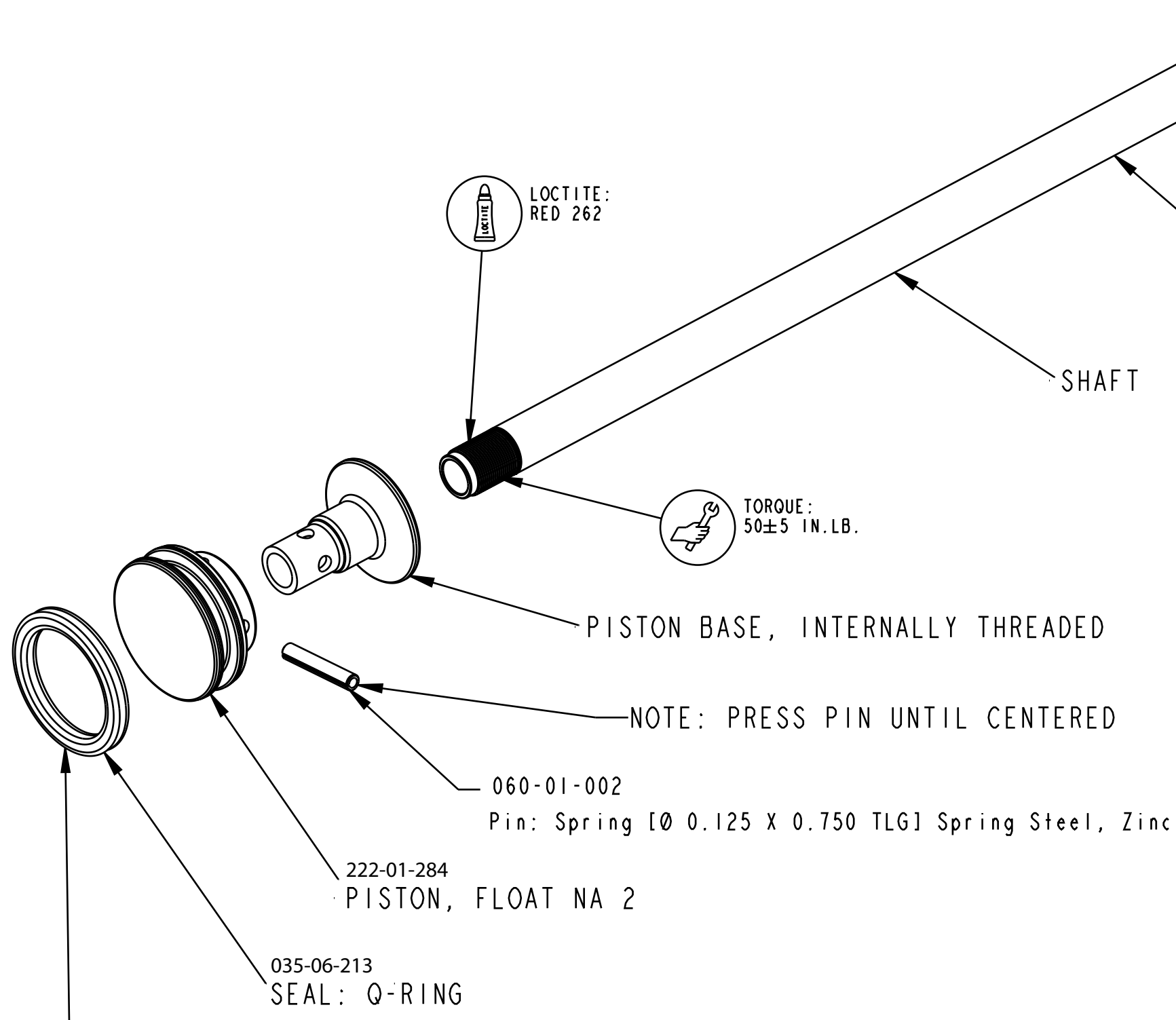
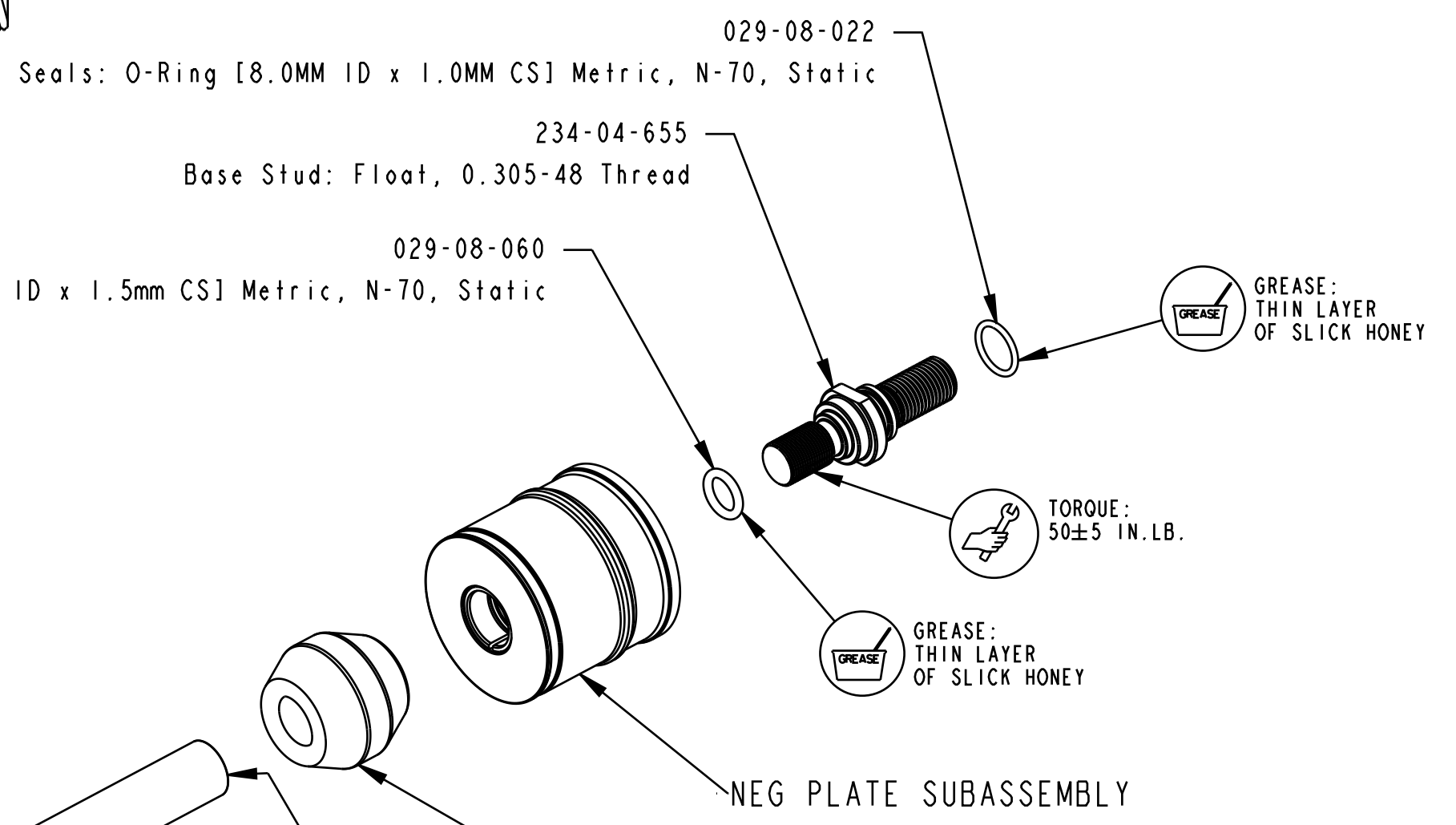

NOTE: VERIFY SEAL IS NOT TWISTED AFTER INSTALL

PROPRIETARY - THIS DOCUMENT CONTAINS CONFIDENTIAL, PROPRIETARY INFORMATION THAT IS FOX PROPERTY. DO NOT DISCLOSE TO OR DUPLICATE FOR OTHERS EXCEPT AS AUTHORIZED BY FOX.

FOX FOX Factory, Inc.		Ph 831-768-1100
130 Hangar Way, Watsonville, CA 95076 USA		Fax 831-768-9312
TITLE Air Shaft, Long Travel, FLOAT NA 2 34mm		
SIZE	DWG. NO.	
C		
PLOT SCALE .00:1	SHEET 1 OF 1	